

WALL CANTILEVER JIB CRANES

FOR MAXIMUM LIFT:

The Wall Cantilever (WC200) provides hoist coverage and 200° rotation for individual use in bays, along walls or columns of plants, or as a supplement to an overhead crane or monorail system. This jib has the advantage of providing maximum lift for the hoist, since it can be installed very close to the underside of the lowest ceiling obstruction.

Two key requirements must be met before applying the Wall Cantilever Series:

- 1) A structurally adequate wall or column to support the jib must exist.
- 2) Sufficient clearance above the boom throughout its arc must exist.

WC200—WALL CANTILEVER

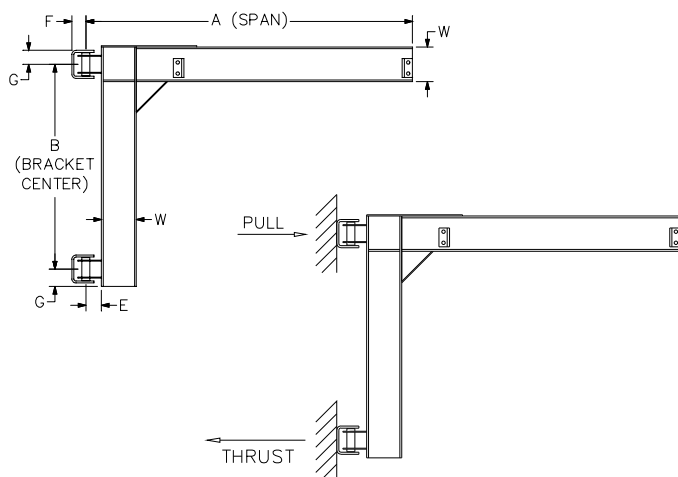

The diagram above details the thrust and pull forces that the jib crane applies to the supporting structure when a load is lifted. It is essential that a structurally adequate wall or column exists to support the jib crane. Refer to the Thrust & Pull chart opposite this page for exact forces.

GORBEL'S ADVANTAGE

EASE OF MOVEMENT

- The fittings containing bronze bushings and oil-impregnated bronze thrust washers which provide for easy rotation and superior load positioning.

SAFETY

- Fabricated steel fittings provide excellent torsional rigidity.
- Pre-engineered for use with powered hoists. A factor of 15% of the jib crane capacity is allowed for the hoist and trolley weight with an additional 25% of the capacity allowed for impact, thus giving maximum capacity use of the jib.

EASE OF INSTALLATION

- When the bracket center dimension is 6'0" or less, the mast/boom connection is welded. This provides the most economical means of installation.
- When the bracket center is greater than 6'0", a bolted mast/boom connection is used, which enables the larger cranes to be shipped disassembled for ease of handling during shipping and installation.
- Grease fittings are provided for easy field lubrication.

200° POWER ROTATION

- Is optional (see page 4 & 5 details).

TOP AND BOTTOM BRACKET FITTINGS

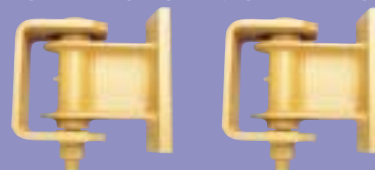

Fitting kits are available for fabrication of cranes locally.

WC200 WALL CANTILEVER

Capacity	A Span	Model Number	B	E	F	G	W	Thrust and Pull
1/4 TON	8'	WC200-B1-8-6	3' 0"	5"	3 1/2"	6"	6"	1767#
	10'	WC200-B1-10-6	3' 0"	5"	3 1/2"	6"	6"	2308#
	12'	WC200-B1-12-6	3' 0"	5"	3 1/2"	6"	6"	2867#
	14'	WC200-B1-14-7	3' 0"	5"	3 1/2"	6"	7"	3533#
	16'	WC200-B1-16-8	3' 0"	5"	3 1/2"	6"	8"	4285#
	18'	WC200-B1-18-8	4' 0"	5"	3 1/2"	6"	8"	3720#
	20'	WC200-B1-20-10	4' 0"	5"	3 1/2"	6"	10"	4595#
1/2 TON	8'	WC200-B1-8-7	3' 0"	5"	3 1/2"	6"	7"	3430#
	10'	WC200-B1-10-7	3' 0"	5"	3 1/2"	6"	7"	4455#
	12'	WC200-B1-12-7	3' 0"	5"	3 1/2"	6"	7"	5501#
	14'	WC200-B1-14-8	4' 0"	5"	3 1/2"	6"	8"	5001#
	16'	WC200-B1-16-10	4' 0"	5"	3 1/2"	6"	10"	6063#
	18'	WC200-B1-18-10	4' 0"	5"	3 1/2"	6"	10"	6979#
	20'	WC200-B1-20-12	6' 0"	5"	3 1/2"	6"	12"	5493#
1 Ton	8'	WC200-B1-8-8	4' 0"	5"	3 1/2"	6"	8"	5047#
	10'	WC200-B1-10-10	5' 0"	5"	3 1/2"	6"	10"	5294#
	12'	WC200-B1-12-10	5' 0"	5"	3 1/2"	6"	10"	6526#
	14'	WC200-B1-14-10	5' 0"	5"	3 1/2"	6"	10"	7778#
	16'	WC200-B1-16-12	6' 0"	5"	3 1/2"	6"	12"	7678#
	18'	WC200-B1-18-16	6' 0"	5"	3 1/2"	6"	16"	9148#
	20'	WC200-B1-20-16	6' 0"	5"	3 1/2"	6"	16"	10367#
2 TON	8'	WC200-B2-8-12	4' 0"	5"	4"	6"	12"	10054#
	10'	WC200-B2-10-12	4' 0"	5"	4"	6"	12"	12998#
	12'	WC200-B2-12-16	4' 6"	5"	4"	6"	16"	14409#
	14'	WC200-B2-14-16	5' 0"	5"	4"	6"	16"	15442#
	16'	WC200-B2-16-18	6' 0"	5"	4"	6"	18"	15067#
	18'	WC200-B2-18-18	6' 6"	5"	4"	6"	18"	15892#
	20'	WC200-B2-20-20	7' 6"	5"	4"	6"	21"	15840#
3 TON	8'	WC200-B3-8-16	4' 0"	5"	4"	6"	16"	15060#
	10'	WC200-B3-10-16	4' 6"	5"	4"	6"	16"	17300#
	12'	WC200-B3-12-16	5' 6"	5"	4"	6"	16"	17389#
	14'	WC200-B3-14-18	6' 0"	5"	4"	6"	18"	19017#
	16'	WC200-B3-16-18	7' 6"	5"	4"	6"	18"	17653#
	18'	WC200-B3-18-20	8' 6"	5"	4"	6"	21"	17982#
	20'	WC200-B3-20-24	9' 6"	5"	4"	6"	21"	18105#
5 TON	8'	WC200-B5-8-18	6' 6"	7"	6"	9"	18"	15323#
	10'	WC200-B5-10-18	6' 6"	7"	6"	9"	18"	19770#
	12'	WC200-B5-12-20	6' 6"	7"	6"	9"	21"	24379#
	14'	WC200-B5-14-20	7' 6"	7"	6"	9"	21"	25077#
	16'	WC200-B5-16-24	9' 6"	7"	6"	9"	21"	22941#
	18'	WC200-B5-18-24	9' 6"	7"	6"	9"	24"	26485#
	20'	WC200-B5-20-24	9' 6"	7"	6"	9"	24"	29769#

Model Number Explanation:

Example : 1 Ton WC200-B1-12-10; 1 Ton = 2,000 pound capacity, WC200 = Wall Cantilever style, 12 = span A, 10 = boom depth in inches (W).

Other Sizes and Capacities

Other spans and capacities are available by contacting your local Gorbels Dealer.

Dimensions are subject to change without notice.