

# Economy Lifting Beams

## Model 16 - Adjustable Spreader/Lifting Beam



### PRODUCT FEATURES:

- Use as 2, 3 or 4 point lifting or spreader beam.
- Converts to spreader beam with addition of top rigging.
- Has adjustable lifting points.
- Can handle both wide and unbalanced loads.
- Low headroom design.
- Shackles included.
- Designed and manufactured to ASME B30.20.

### PRODUCT OPTIONS:

- Pair of swivel hooks - Code S
- Chain top rigging - Code C
- Cross beams (one or two) specify spread(s) - Consult factory

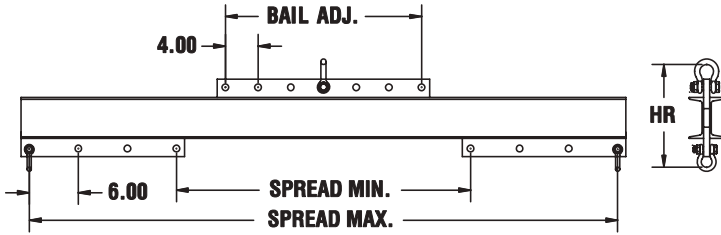

### SPECIFICATIONS

Model Number	Rated Capacity (tons)	Spread (in.)		Bail Adj. (in.)	Headroom (in.)	Bolt Type Anchor Shackle (tons)		Optional Swivel Hook (tons)	Weight (lbs.)
		Max	Min			Top	Bottom		
16-1/4-4	1/4	48	12	16	7.1	1 1/2	1 1/2	1	37
16-1/2-6	1/2	72	36	24	7.75	1 1/2	1 1/2	1	76
16-1-6	1	72	36	24	7.75	1 1/2	1 1/2	1	76
16-2-6	2	72	36	24	12.6	3 1/4	2	2	128
16-4-8	4	96	48	32	16.6	4 3/4	4 3/4	4-1/2	270
16-5-10	5	120	60	40	20.2	6 1/2	4 3/4	4-1/2	445
16-7-12	7	144	72	48	23.8	8 1/2	6 1/2	7	755

## Operation

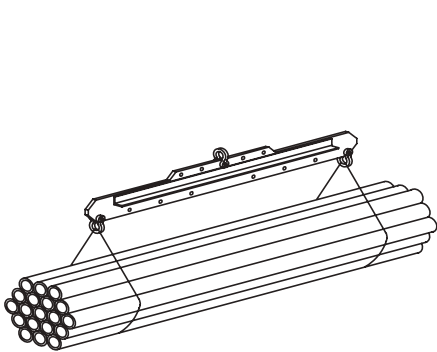

2 Point Lift

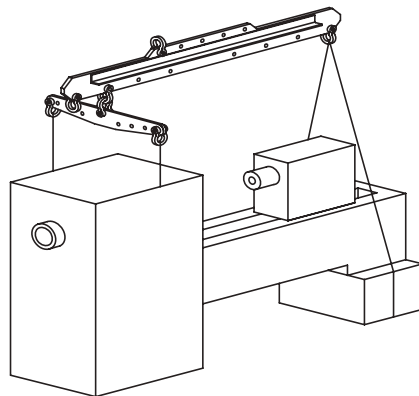

3 Point Lift

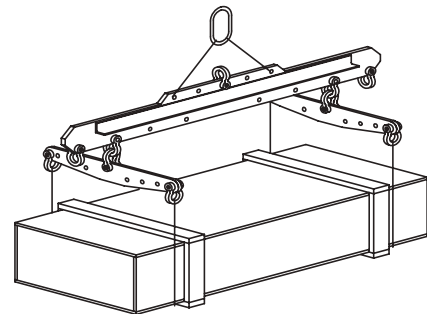

4 Point Lift

